

High
Quality
Heavy Duty
Art

DIXON Valves

IMFLUID Ltda.

Compañía N° 1973, Santiago, Chile

Central (fax) : 56-02-6967479

MODEL NO: DX PN16

1-PC STAINLESS STEEL FLANGE END
INVESTMENT CASTING, FULL PORT, SOLID BALL
ANTI-STATIC DEVICE, FIRE-SAFE DESIGN
BODY & CAP IN ASTM A351 -CF8M
TRIM IN ASTM SS316
SEATS IN PTFE
FLANGE TO PN16/PN40
MOUNTING PAD FOR ISO 5211
BLOW-OUT PROOF STEM, LEVER OPERATED

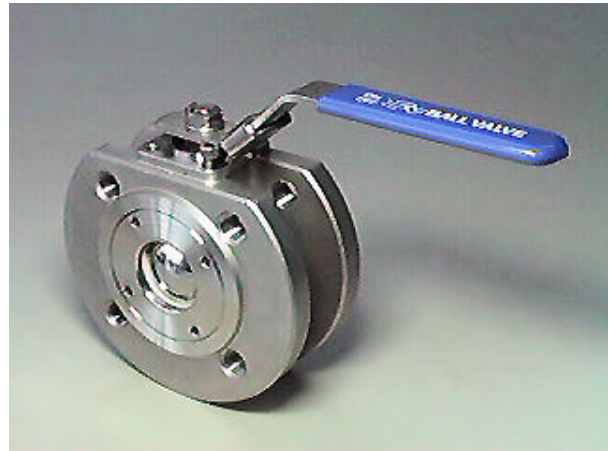

DIMENSIONS LIST:

MM	INCH	D	E	H	L	N	O	P	A	B	F	W	X	Y	M	H1
15	1/2	15	135	82	38	65	95	39	34	16	2	6.3	25	36	M5	18
20	3/4	20	135	86	38	75	105	42.5	37.5	18	2	6.3	25	36	M5	17.5
25	1	25.4	165	98	46	85	115	52	47	18	2	8	30	42	M5	20
30	1-1/4	32	165	102	54	100	140	52.2	51.5	18	3	8	35	50	M6	20
40	1-1/2	38	200	119	64	110	150	66	58	18	3	9.5	55	70	M8	23.5
50	2	50	200	128	82	125	165	75	67	20	3	9.5	55	70	M8	23.5
65	2-1/2	65	250	162	94	145	185	89.5	79.5	18	3	17	70	102	M10	41.5
80	3	80	250	172	118	160	200	102.5	92.5	20	3	17	70	102	M10	41.5
100	4	100	300	197	140	180	220	123.5	113.5	20	3	17	70	102	M10	41.5

MATERIALS SPECIFICATION :

1	BODY	ASTM A351 CF8M
2	BODY SEAL	PTFE
3	SEAT RETAINER	ASTM A351 CF8M
4	BALL SEAT	PTFE
5	SOLID BALL	ASTM A351 CF8M
6	STEM	SS316
7	STEM SEAL	50% PTFE +50% STAINLESS STEEL POWDER
8	STEM PACKING	PTFE
9	THRUST WASHER	50% PTFE +50% STAINLESS STEEL POWDER
10	FOLLOWER	SS304
11	BELLEVILLE WASHER	SS301
12	NUT	SS304
13	SADDLE WASHER	SS304
14	SPRING WASHER	SS304
15	HANDLE	SS304
16	GRIP	VINYL

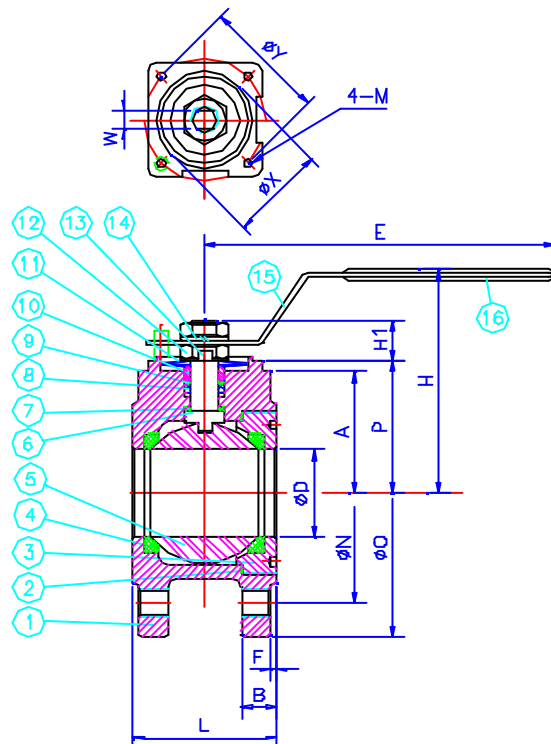

We hereby reserve the rights of any alternative dimension that would help to improve our valve's quality and working efficiency